

Joint Research Centre

Achieving Massive Multilinguality

"Acquis Communautaire" - Term Extraction and Alignment

Exploiting « Acquis Communautaire » - parallel corpora in up to 20 languages

Available at <http://wt.jrc.it/lt/acquis/>

One aligned sentence in 21 languages (subset of a parallel corpus), with two terms highlighted

en: <P>(11) The measures provided for in this Regulation are in accordance with the opinion of the Management Committee for Pigmeat.</P>
 bg: 11. Мерките, съгласно тази регламент са в съответствие със становището на Управителния комитет за свинско месо.</P>
 ca: <P>(11) L'aplicació dels mesures establertes en aquest Reglament és conforme amb l'opinió del Comitè de gestió de la carn de porcino.</P>
 da: <P>(11) De denne forordning fastsatte foranstaltninger er i overensstemmelse med udtalelse fra Forvaltningskomiteen for Svinekød.</P>
 de: <P>(11) Die in dieser Verordnung vorgesehenen Maßnahmen entsprechen der Stellungnahme des Verwaltungsausschusses für Schweinefleisch.</P>
 el: <P>(11) Τα μέτρα που προβλέπονται στον παρόντα κανονισμό είναι σύμφωνα με τη γνώμη της επιτροπής διαχείρισης χοιρέιου κρέατος.</P>
 es: <P>(11) Las medidas previstas en el presente Reglamento se ajustan al dictamen del Comité de gestión de la carne de porcino.</P>
 fi: <P>(11) Käsiteltävien määruksien toteuttaminen on suostunut hallintokomitean lausuntoon mukaisesti.</P>
 fr: <P>(11) Les mesures prévues par le présent règlement sont conformes à l'avis du comité de gestion de la viande de porc.</P>
 hu: <P>(11) Az e rendeleiben előírt rendelkezések összhangban vannak a Szénhidrátügyi irányítóbizottság véleményével.</P>
 it: <P>(11) Le misure previste dal presente regolamento sono conformi al parere del comitato di gestione per le carni suine.</P>
 lv: <P>(11) Kadangi šīame regulējumā numatātas pasākumi atbilst Kaulienu vadības komitejas rekomendācijām.</P>
 lt: <P>(11) Šajā reguli pavadžtie pasākumi ir saskaņā ar Cūkgaļas vadības komitejas atzinumu.</P>
 mt: <P>(11) Ili-mizuri li għallhom hemm provvediment f'dan ir-Regolament huma bi qbil ma 'l-opinjoni tal-Kumitat ta' Gestjoni war il-Laham tal-Majjal.</P>
 nl: <P>(11) De in deze verordening vervatte maatregelen zijn in overeenstemming met het advies van het Comité van beheer voor varkensvlees.</P>
 pl: <P> 11) Środki przewidziane w niniejszym rozporządzeniu są zgodne z opinią Komitetu Zarządzającego ds. Wiedprzowiny.</P>
 pt: <P>(11) As medidas previstas no presente regulamento estão em conformidade com o parecer do Comité de Gestão da Carne de Suíno.</P>
 sk: <P>(11) Opatrenia ustanovené v tomto nariadení sú v súlade so stanoviskom Riaditeľného výboru pre bravčové mäso.</P>
 sv: <P>(11) Ukrepi, določeni s to uredbi, so v skladu z mnenjem Upravljalnega odbora za prašičje meso.</P>
 sv: <P>(11) De åtgärder som föreskrivs i denna förordning är förenliga med yttrandet från Förvaltningskommittén för griskött.</P>

Multilingual Domain-Specific Terminology

Term highlighted in a text

natural uranium
 FR: uranium naturel,
 DE: natürliches Uran

CN_codes	Product_definition
2844100000	"Natural uranium and its compounds, alloys, dispersion systems or natural uranium compounds"
731815410010	"Other, with a tensile strength"
8518102000	"Microphones having a frequency range of 300 Hz to 3,4 KHz, of a diameter not exceeding 10 mm and a height not exceeding 3 mm, of a kind used for telecommunications"
730630210020	"Precision tubes, with a wall thickness"
2806100000	"Hydrogen chloride (hydrochloric acid)"
392099530000	"Ion-exchange membranes of fluorinated plastic material, for use in chlor-alkali electrolytic cells"
392099530000	"Ion-exchange membranes of fluorinated plastic material, for use in chlor-alkali electrolytic cells"
8456000000	"Machine tools for working any material by removal of material, by laser or other light or photon beam, ultrasonic, electrodischarge, electrochemical, electron beam, ion-beam or plasma arc processes"
7219000000	"Flat-rolled products of stainless steel, of a width of 600 mm or more"
845699100000	"Focused ion beam milling machines for producing or repairing masks and reticles for patterns on semiconductor devices"
850450300000	"Of a kind used with telecommunication apparatus and for power supplies for automatic data-processing machines and units thereof"

Visualization of a the context of the term

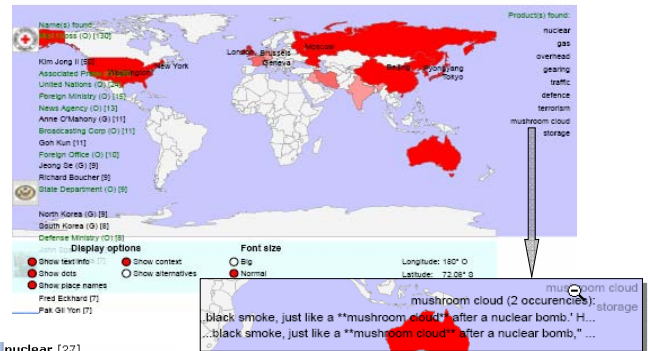

Automatic Generation of Term Translations

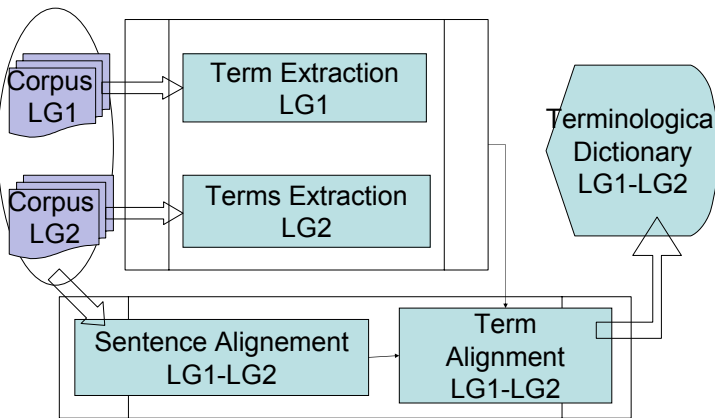

Term Extraction

English Term	Score (EN)	French Term	Score (FR)	German Term	Score (DE)
european community	90.22	communauté européenne	132.71	europäisch gemeinschaft	166.63
official journal	46.52	etat membre	78.26	regierung [d] mitgliedstaat	101.15
steel community	43.49	soin [de la] conseil	77.68	interne abkommen	48.63
european parliament	43.49	agence européenne	50.82	vertreter [d] regierung	42.20
particular article	43.49	parlement européen	44.42	europäisch zentralbank	40.70
base [of the] proposal	43.49	base [de la] proposition	44.42	europäisch parlament	40.70
government [of the] member	38.37	accord international	36.86	europäisch union	40.70
court [of] justice	37.92	recherche [de la] charbon	35.05	bestimmung [d] interne	32.27
international agreement	36.02	litre provisoire	35.05	europäisch amt	26.73
steel industry	34.35	industrie [de la] charbon	35.05	europäisch polizeiakademie	23.14
wilm dunsenberg	34.35	accord interne	33.42	europäisch atomgemeinschaft	23.14
escs treaty	30.44	traite coca	31.23	durchführung [d] programmierung	23.14
liability [of the] escs	26.67	union européenne	29.42	europäisch rat	23.14
transitional measure	26.66	patrimoine actif	27.26	wahrung [d] euro	23.14

Cross-lingual Glossing

hieved as provided in this Treaty and in accordance with th
 ecting the principle of subsidiarity (načelo subsidiarnosti)
 European Community (Europska zajednica).